

Körperschalllautsprecher EXT-5012J16 Art. Nr. 105001

Specification:

NO	ITEM	SPECIFICATION
1	Mechanical Layout & Dimensions	Shown in the Exciter-02.Drw
2	Nominal Impedance	$8 \Omega \pm 15\%$ at 1KHZ, 1.0V (D.C.R= $7.2\Omega \pm 10\%$)
3	Input Power	Nom. Input 5W
		Max. Input 10W
4	Operation	4.47Volt (268Hz-20KHz) Sweep Time at 2s
5	Resonant FerQ. F0	$335 \pm 20\%$ HZ (F0 Meter)
6	Flux Density	12000 GAUSS $\pm 10\%$
7	Insulation Resistance	No Less than 1M at DC 100V
8	Polarity	When positive voltage is applied to the (+) Terminal, Voice Coil should move out to of the Air gap.
9.	Weight	$60g \pm 10\%$ (Driver weight)
10	Power Test	IEC 268-5 6.32V 48 Hours
11	Heat Resistance	Temperature: $+60^{\circ}\text{C} \pm 2^{\circ}\text{C}$ Duration: 24 hours
12	Humidity Resistance	Temperature: $+40^{\circ}\text{C} \pm 2^{\circ}\text{C}$ Relative Humidity: 93(+2/-3)% Duration: 48 Hours(GB)
13	Low Resistance	Temperature: $-10^{\circ}\text{C} \pm 3^{\circ}\text{C}$ testing 1 Hours (GB) And then $-20^{\circ}\text{C} \pm 3^{\circ}\text{C}$ testing 2 Hours(GB)
14	Dropping Test	$600 \pm 25\text{mm}$ $60^{\circ} \pm 5^{\circ}$ (GB)

Körperschalllautsprecher EXT-5012J16 Art. Nr. 105001
Sample Testing Report:

NO	ITEM	TESTING CONDITIONS	No1	No2	No3	No4	Result
1	Speaker Size	Out Diameter : Φ 48 \pm 0.3mm	48	48	/	/	OK
2	Impedance	8 Ω \pm 15 % At 1KHZ,1.0V (D.C.R: 7.2 Ω \pm 10%)	7.2	7.2	/	/	OK
3	Resonance Frequency	335Hz \pm 20% (F0 Meter)	335	335	/	/	OK
4	Buzz & Rattle Test	Must Be Normal: Wave4.47V (Form 268Hz To 20KHz)	√	√	/	/	OK
5	Polarity	When a positive D.C voltage is applied To the voice coil terminal marked to Diaphragm should move to the front	√	√	/	/	OK
6	Flux Density	12000GAUSS \pm 10%	12000	12100	/	/	OK
7	Power Test	IEC 268-5 6.32V 48 Hours	√	√	/	/	OK
8	Heat Resistance	Temperature: +60°C \pm 2°C Duration: 24 Hours	√	√	/	/	OK
9.	Humidity Resistance	Temperature: +40°C \pm 2°C Relative Humidity: 93(+2/-3)% Duration: 48 Hours(GB)	√	√	/	/	OK
10	Low Temperature	Temperature: -10°C \pm 3°C testing 1 Hours And then -20°C \pm 3°C testing 2 Hours(GB)	√	√	/	/	OK
11	Dropping Test	600mm \pm 25mm 60° \pm 5° (GB)	√	√	/	/	OK

Körperschalllautsprecher EXT-5012J16 Art. Nr. 105001

RoHS Substance Confirmation Form:

NO	SUPPLY ITEM		RoHS Substance Inspection Result						Survey Report No
			Cd	Pb	Hg	Cr6+	PBB	PBDE	(6 Material)
	Item	Material	100	1000	1000	1000	1000	1000	Ppm
1	Magnet	N35	ND	ND	ND	Negative	ND	ND	GZ1103028813/CHEM
			OK	OK	OK	OK	OK	OK	2011/03/23
2	U cup	Fe	ND	ND	ND	Negative	ND	ND	RLSDC000024190002C
			OK	OK	OK	OK	OK	OK	2010/05/10
3	Washer	Fe	ND	ND	ND	Negative	ND	ND	RLSDC000024190002C
			OK	OK	OK	OK	OK	OK	2010/12/28
4	Voice coil	KSV	ND	ND	ND	ND	ND	ND	RLSZC000740530003
			OK	OK	OK	OK	OK	OK	2010/11/24
5	Damper	/	ND	ND	ND	ND	ND	ND	CE/2009/C6892
			OK	OK	OK	OK	OK	OK	2010/10/07
6	Terminal	/	ND	ND	ND	Negative	ND	ND	CE/2011/12724
			OK	OK	OK	OK	OK	OK	2011/10/20
7	Coupling ring	PC	ND	ND	ND	ND	ND	ND	CE/2010/72470A
			OK	OK	OK	OK	OK	OK	2010/01/19
8	Glue	/	ND	ND	ND	ND	ND	ND	CE/2011/35351
			OK	OK	OK	OK	OK	OK	2011/03/28

Körperschalllautsprecher EXT-5012J16 Art. Nr. 105001

Dimension:

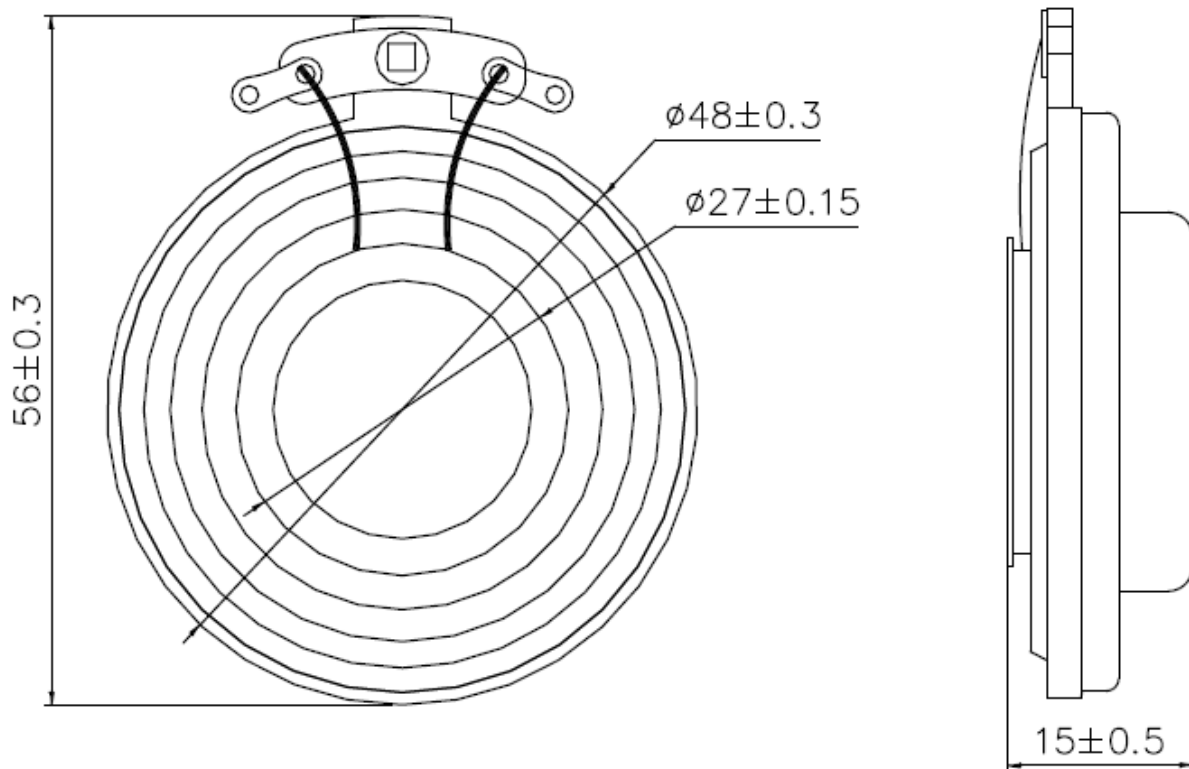

Körperschalllautsprecher EXT-5012J16 Art. Nr. 105001

